

LAGUNA

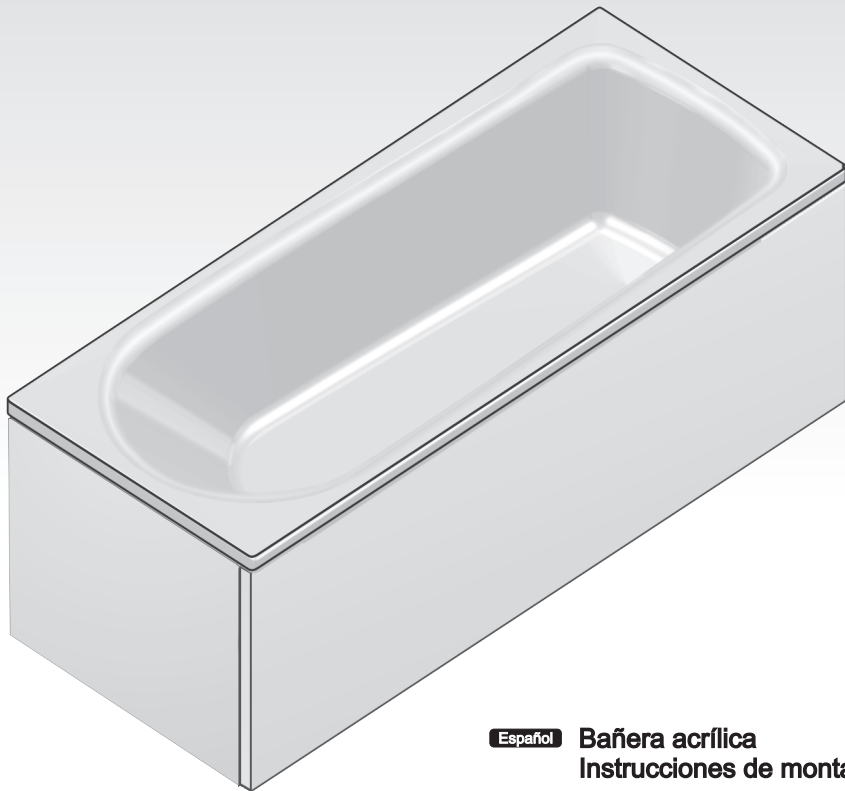

Español Bañera acrílica
Instrucciones de montaje

English Acrylic bathtub
Installation instructions

gala

BAÑERA ACRÍLICA - ACRYLIC BATHTUB

Fig-1

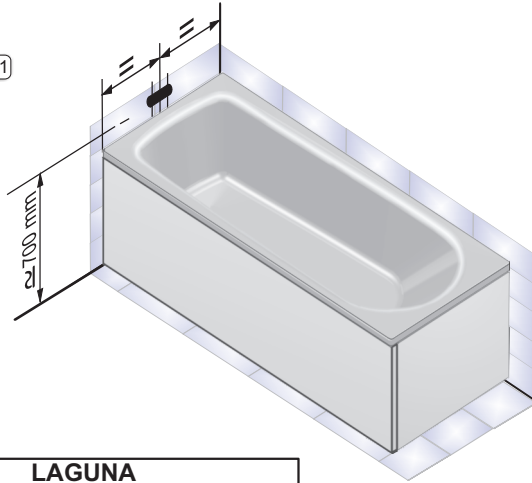

LAGUNA						
A	B	C	D	D'	E	E'
1700	750	250	555	555-575	130	130-150
1700	700	250	555	555-575	130	130-150
1600	700	250	555	555-575	130	130-150

D-E: (con faldón) / (with apron)
D'-E': (sin faldón) / (without apron)

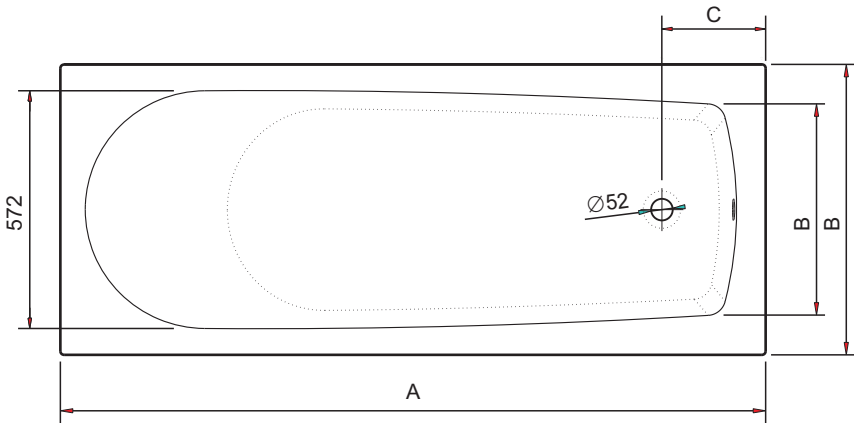
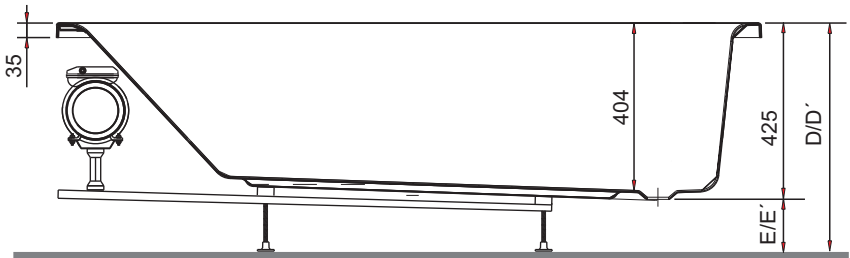

INSTALACIÓN BASTIDOR - INSTALLATION METAL FRAME

- 1
- 2
- 3

Únicamente para bañeras (sin hidromasaje) con el bastidor sin fijar
 Only for bathtubs (without hydromassage) with not fixed metal frame

1

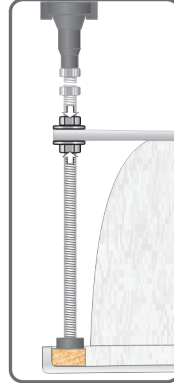
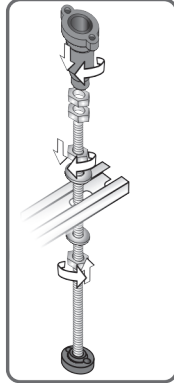
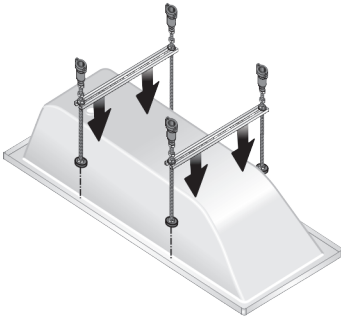

2

	a	b	c
1700x750/700	250	670	505
1600x700	150	670	505

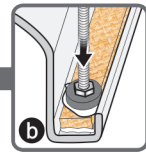
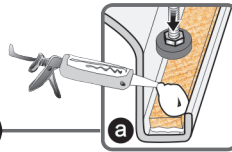
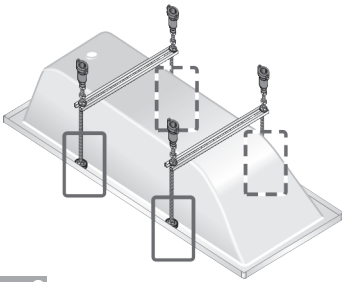
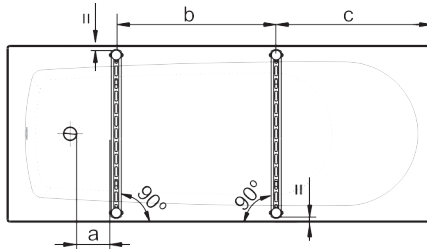

3

x4

Inox 5x20 DIN 7505-A

Inox M8 DIN 9021

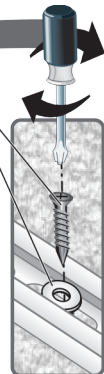
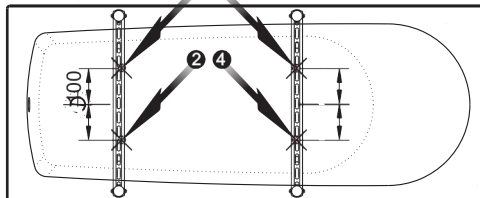
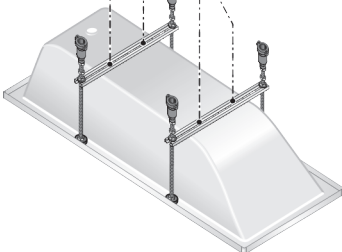

INSTALACIÓN BAÑERA , BATH-TUB INSTALLATION

Español

Proteger la bañera antes de proceder a su instalación.

Realizar el tendido de tuberías de alimentación y desagüe situando la grifería según, Fig-1.

Revestir paredes y suelo.

Colocar los soportes de apoyo (no suministrados) distribuyéndolos uniformemente y depositar silicona según Fig-2.

Antes de colocar la bañera en su emplazamiento, montar la grifería. (La ubicación que se muestra en Fig. 1 es únicamente a título orientativo).

Colocar la bañera. **Regular la altura y nivelar.**

Fijar los pies al suelo.

Conectar el desagüe intercalando un elemento elástico.

Efectuar el revestimiento mural de la bañera o, en su caso, montar el faldón.

Llenar la bañera de agua y sellar las uniones con silicona según Fig-3.

Sin pies:

En las bañeras instaladas sin soporte metálico, deberá realizarse la obra necesaria con ladrillos o lecho de arena.

English

Protect the bathtub before its installation.

Install the water supply and drainage piping, placing the taps as shown in Fig-1.

Install floor and wall coverings.

Place supports (not included) uniformly and apply silicone as shown in Fig-2.

Before positioning the bathtub, install the taps. (The position showed in Fig-1 is only a guide).

Place the bathtub. **Regulate height and set level.**

Position the legs and secure them to the floor.

Connect the drainage pipe using an elastic joint.

Build the bathtub fronting or, if applicable, install the skirting.

Fill the bathtub with water and seal all joints with silicone, as shown in Fig-3.

Without legs:

For steel bathtubs without a metal support structure, mounting must be performed with bricks or sanded.

El sistema de aspiración irá siempre en la parte accesible de la bañera.

The aspiration system of the bathtub must be placed in the accessible part, in order to permit easy servicing.

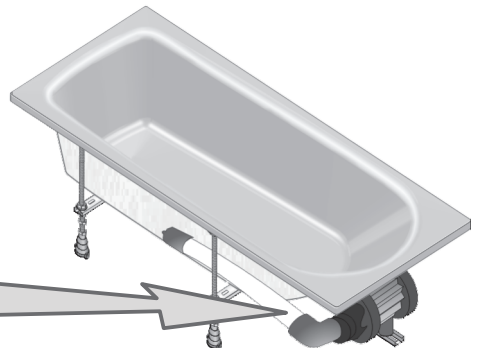

INSTALACIÓN PARA BAÑERA SIN EMPOTRAR
INSTALLATION FOR NOT BUILT-IN BATH-TUB

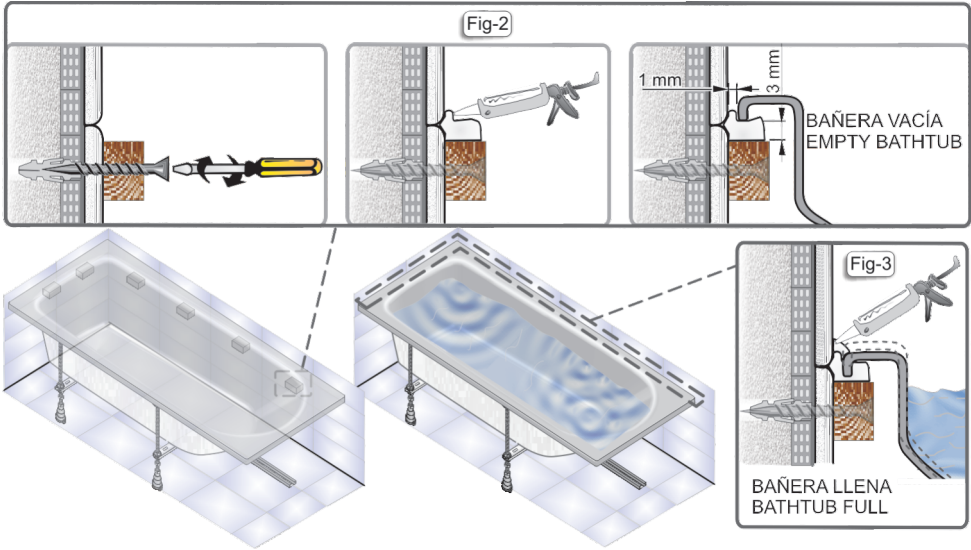

INSTALACIÓN PARA BAÑERA EMPOTRADA
INSTALLATION FOR BUILT-IN BATH-TUB

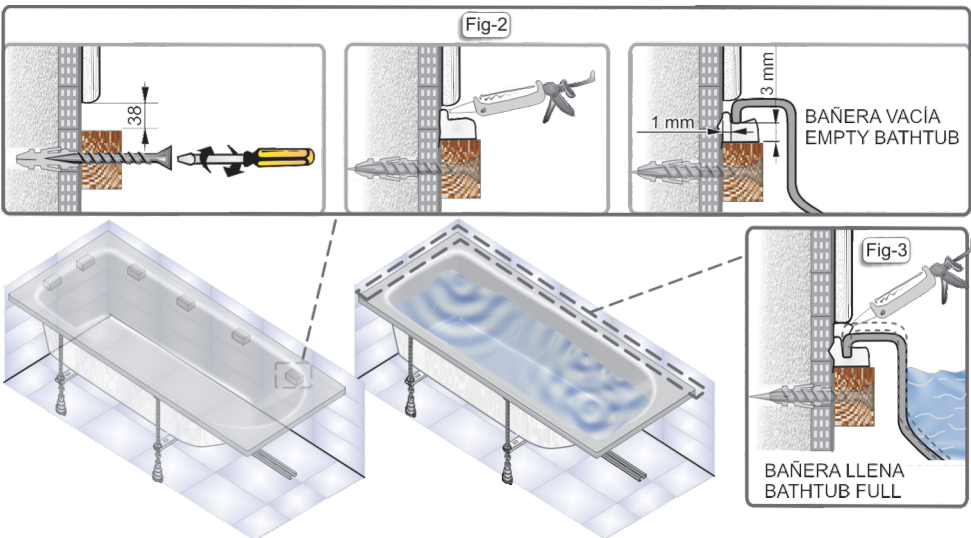

INSTALACIÓN FALDÓN FRONTAL - INSTALLATION OF FRONTAL PANEL

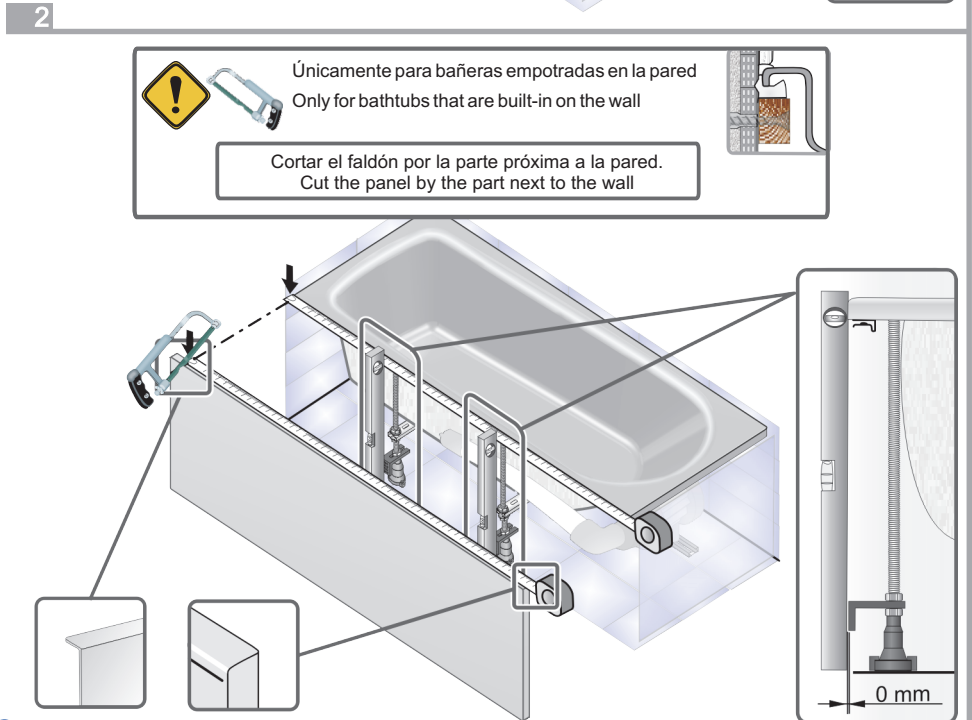
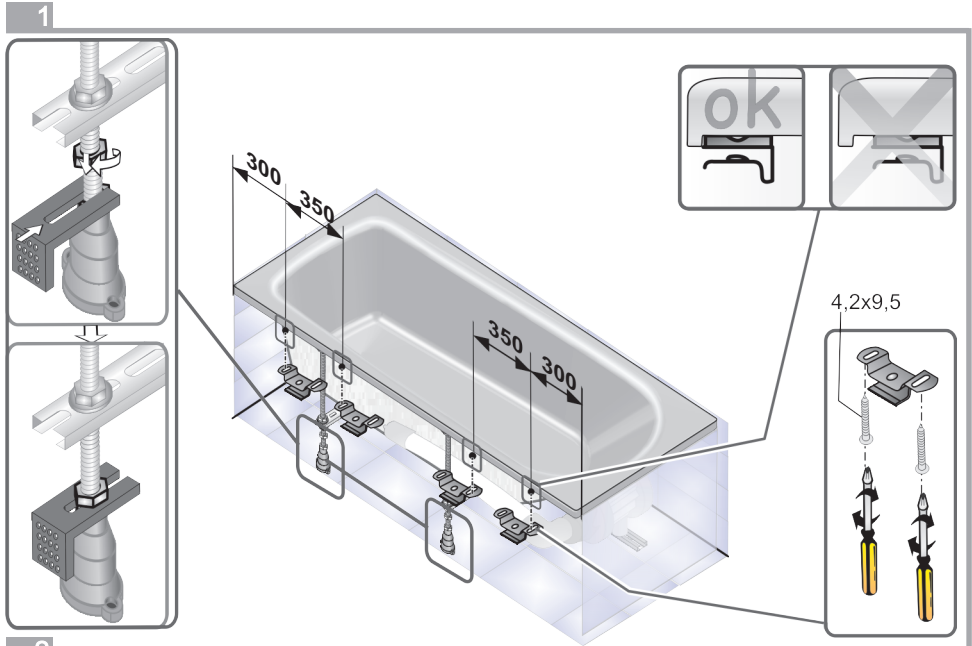

3

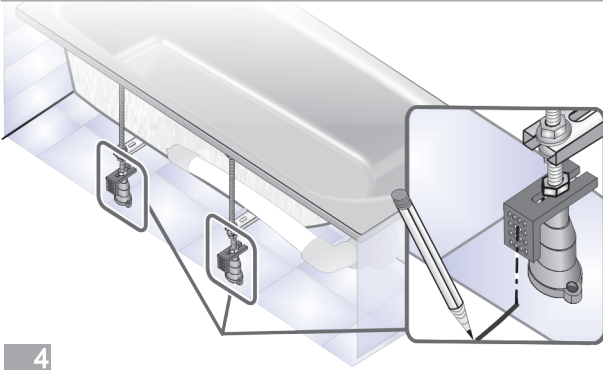

Fijar **todas** las patas al suelo
Secure **all** the legs to the floor

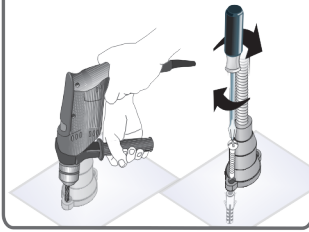

4

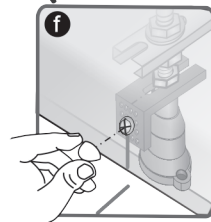
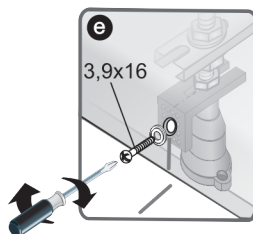
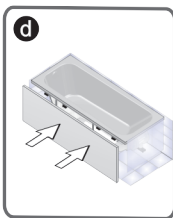
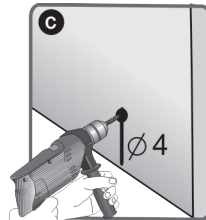
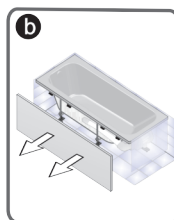
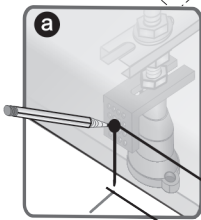
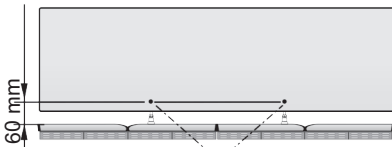
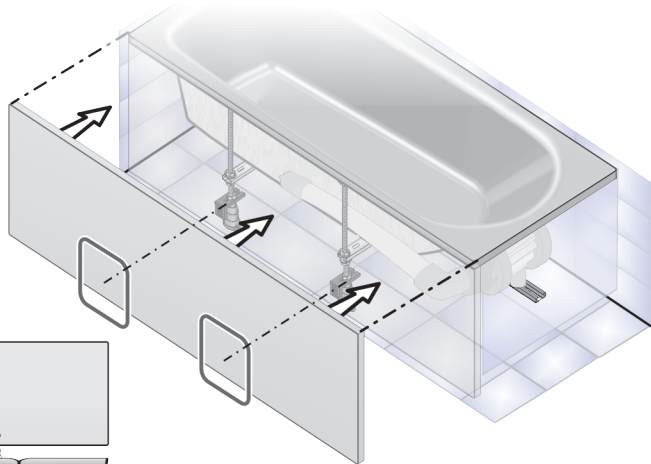

INSTALACIÓN FALDÓN LATERAL DERECHO - INSTALLATION OF SIDE RIGHT PANEL

5

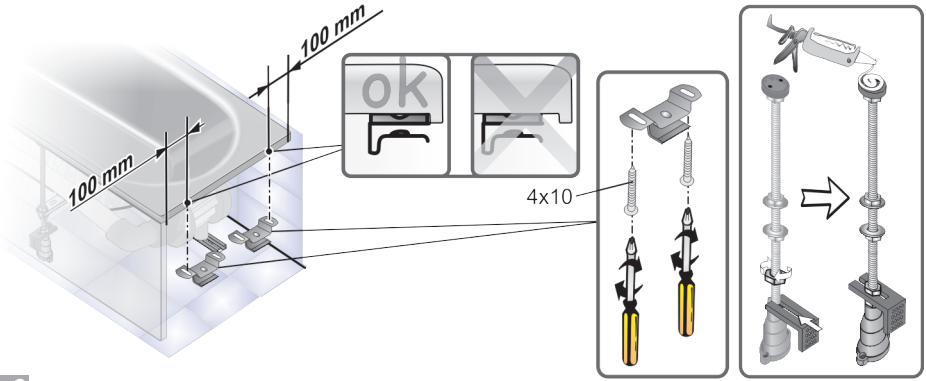

6

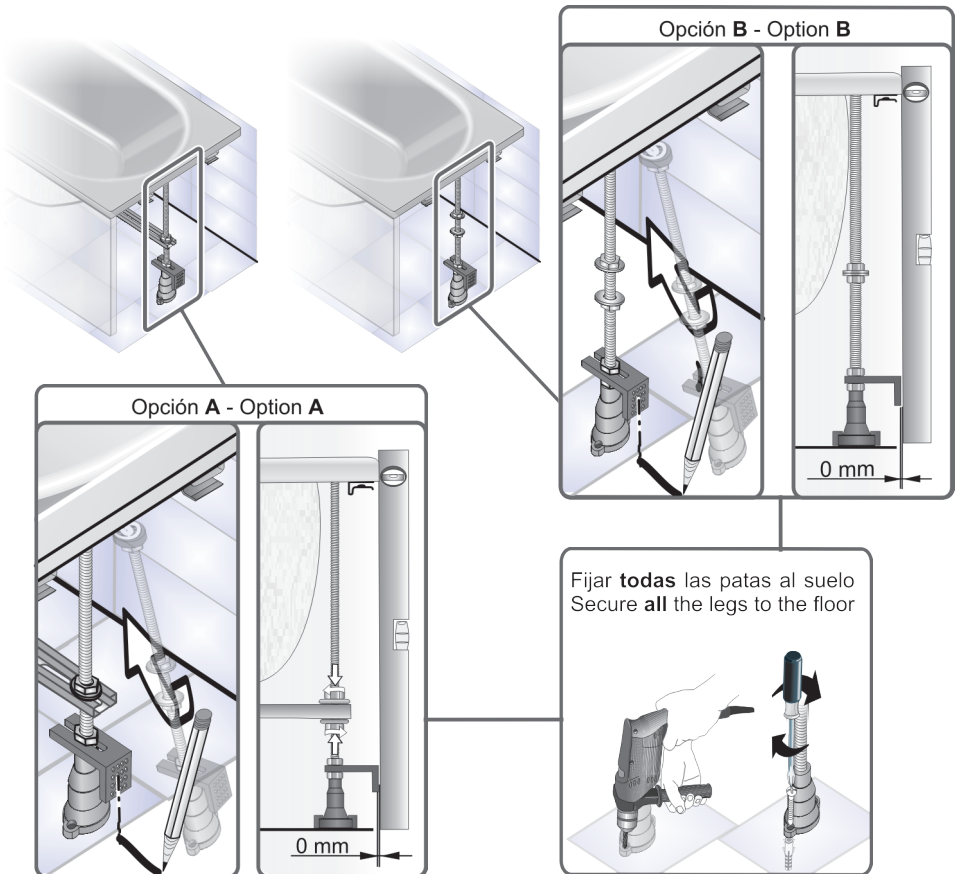

7



7 Únicamente para bañeras empotradas en la pared

7 Only for bathtubs that are built-in on the wall

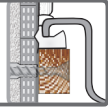

Cortar el faldón por la parte próxima a la pared.
Cut the panel by the part next to the wall

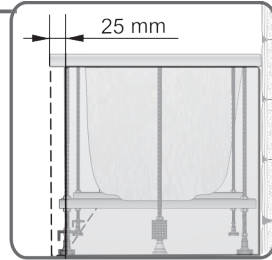
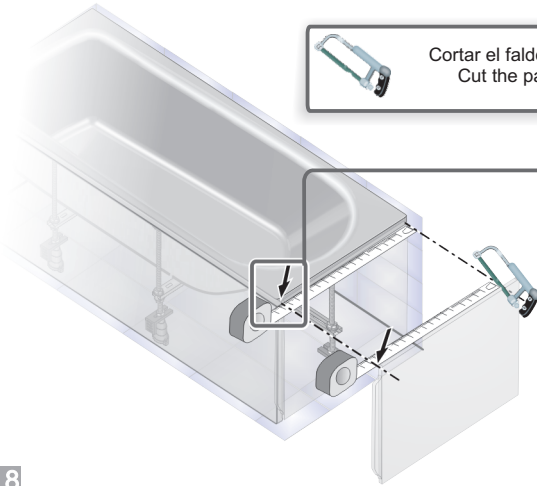

8

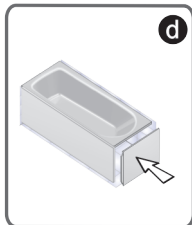
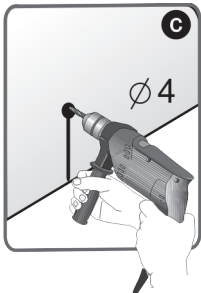
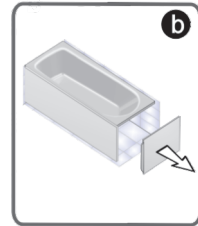
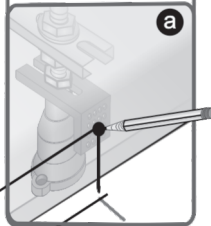
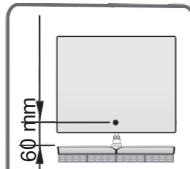
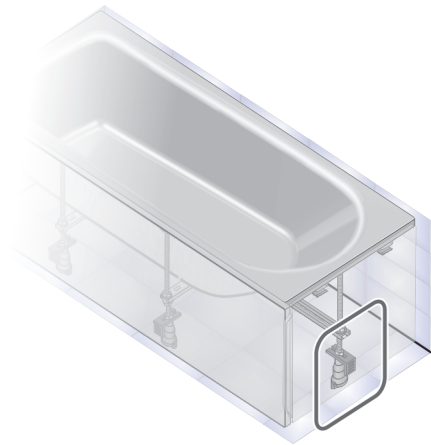

60 mm

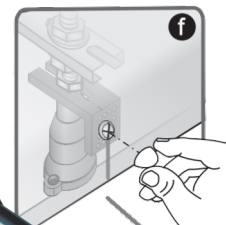
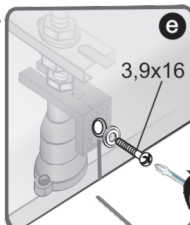

9

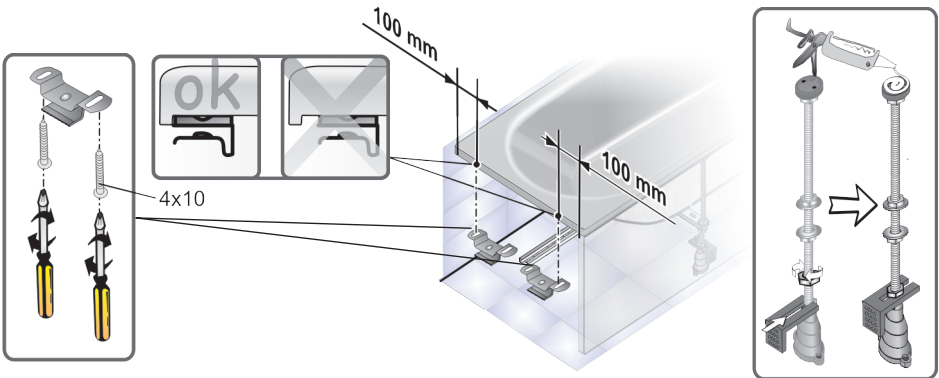

10

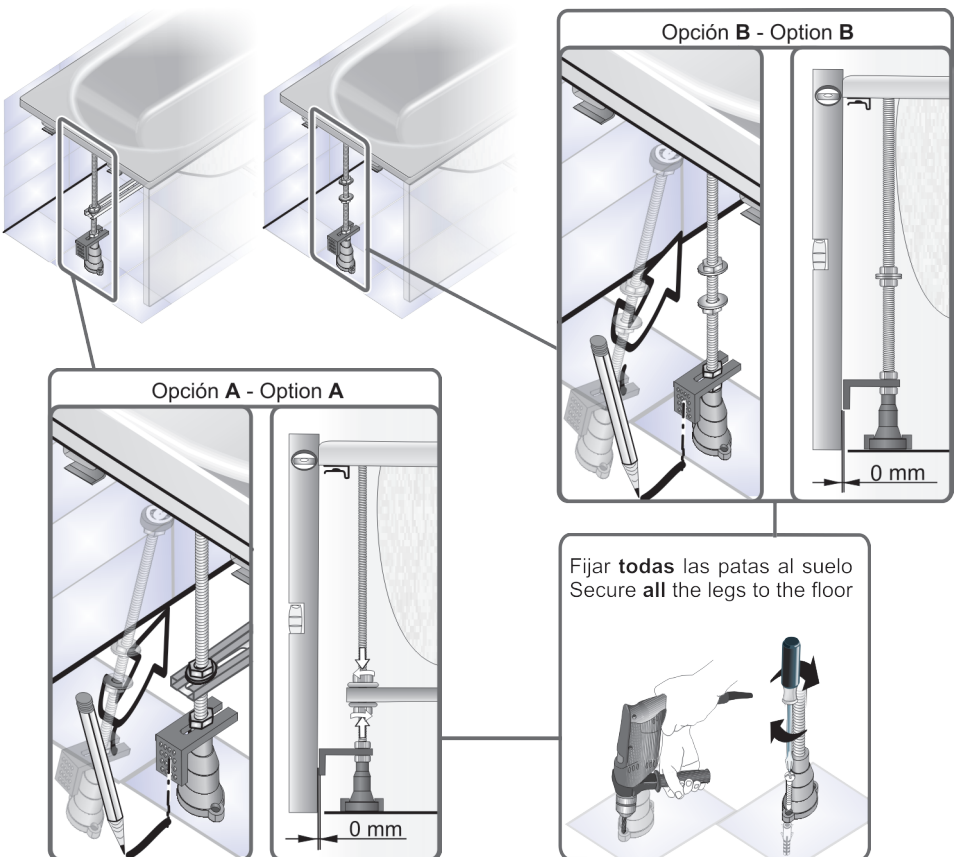

11



11 Únicamente para bañeras empotradas en la pared

11 Only for bathtubs that are built-in on the wall



Cortar el faldón por la parte próxima a la pared.
Cut the panel by the part next to the wall

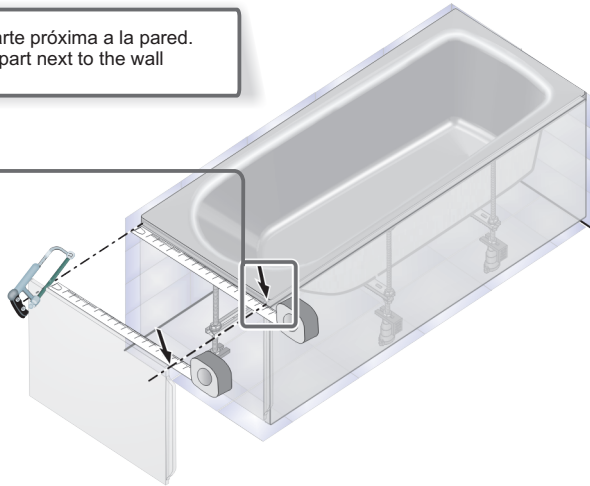
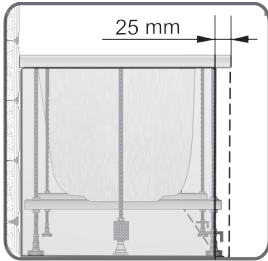

11

12

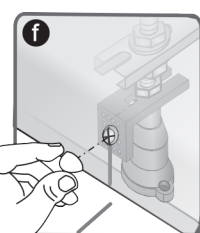
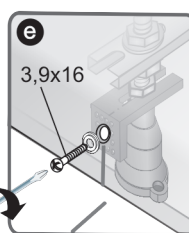
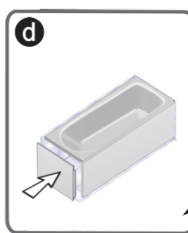
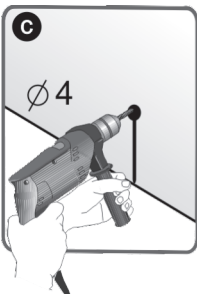
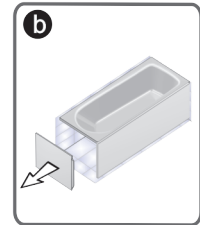
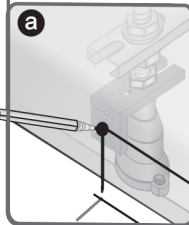
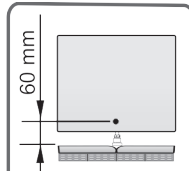
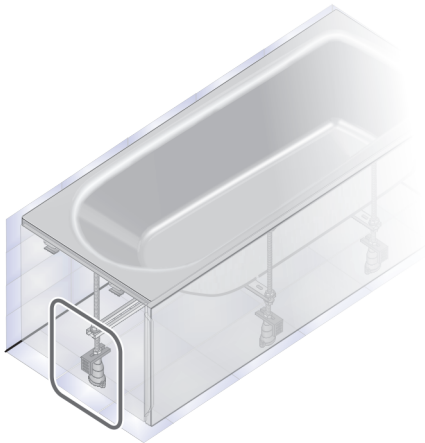

gala

CERÁMICAS GALA, S.A.

Ctra. Madrid - Irún, Km. 244
Apartado de Correos, 293
09080 BURGOS - ESPAÑA
www.gala.es

 +34-947 47 41 00

 +34-947 47 41 03

e-mail: general@gala.es

24416 - 06/08/10